

OV10, 11, 12, 13

Telescopic and foldable ramps

- Lightweight, telescopic and foldable loading ramp series
- Loading capacity up to 500 kg (1102 lbs)
- Maximum extended length up to 2900 mm (114.17")
- Anodized anti-slip surface
- Quick & simple operation

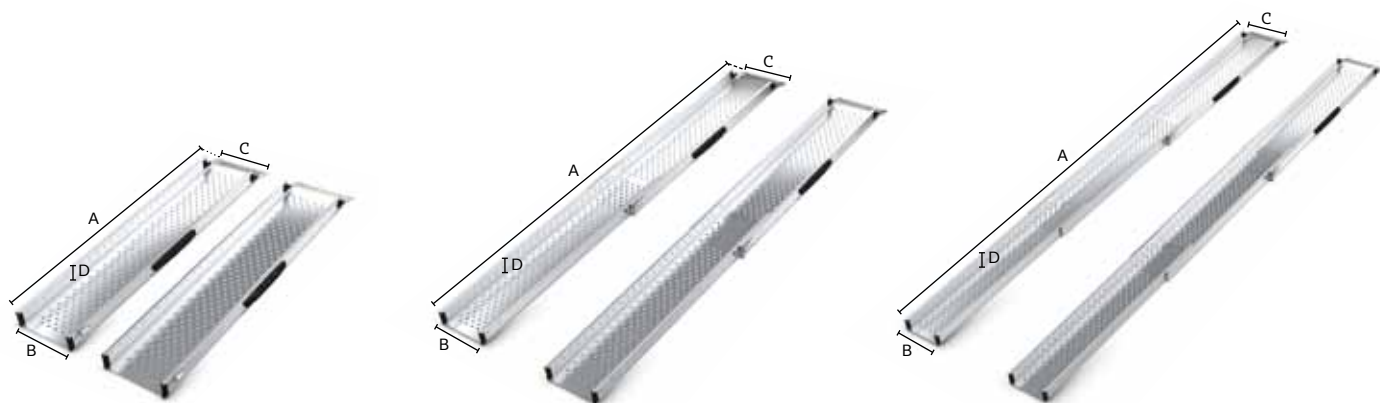

OV10 Telescopic ramps

Code	Description	Electric wheelchair use
OV10E-1-1180	Ramp - 1 piece	NO
OV10E-2-2040	Telescopic ramp - 2 pieces	NO
OV10E-3-2900	Telescopic ramp - 3 pieces	NO

mm in

Technical specifications

Minimum length	Maximum length A	Internal width B	External width C	Side height D	Recommended height (13°)	Loading capacity (SWL*) pair	Weight per piece
							kg lbs
1180 (46.46)	1180 (46.46)	210 (8.27)	236 (9.29)	60 (2.36)	200 (7.87)	500 (1102.10)	3.4 (7.49)
1180 (46.46)	2040 (80.31)	190 (7.48)	236 (9.29)	60 (2.36)	400 (15.75)	320 (705.34)	6.4 (14.11)
1180 (46.46)	2900 (114.17)	170 (6.69)	236 (9.29)	60 (2.36)	600 (23.62)	260 (573.09)	9.0 (19.84)

*SWL calculated for 500mm wheelbase

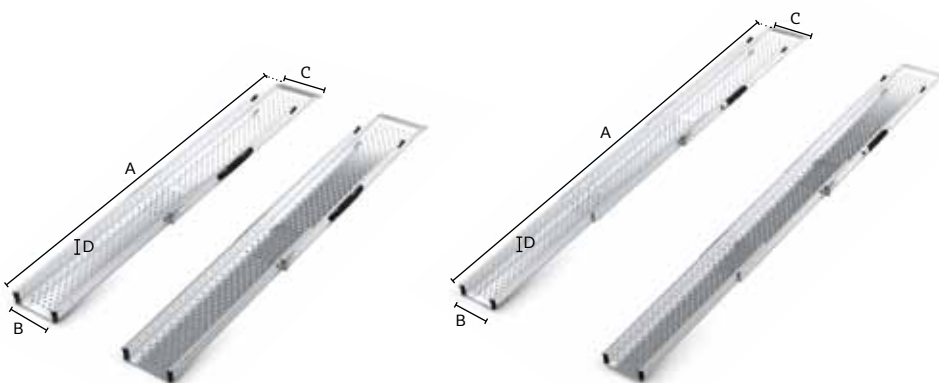
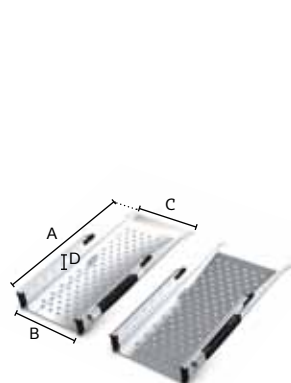

OV11 Telescopic ramps

Code	Description	Electric wheelchair use
OV11E-1-550	Ramp - 1 piece	YES
OV11E-1-1150	Ramp - 1 piece	YES
OV11E-2-1840	Telescopic ramp - 2 pieces	YES
OV11E-3-2530	Telescopic ramp - 3 pieces	YES

mm in

Technical specifications

Minimum length	Maximum length A	Internal width B	External width C	Side height D	Recommended height (13°)	Loading capacity (SWL*) pair	Weight per piece
							kg lbs
550 (21.65)	550 (21.65)	210 (8.27)	236 (9.29)	60 (2.36)	100 (3.94)	540 (1190.27)	1.6 (3.53)
1150 (45.28)	1150 (45.28)	210 (8.27)	236 (9.29)	60 (2.36)	200 (7.87)	500 (1102.10)	3.5 (7.71)
1150 (45.28)	1840 (72.44)	190 (7.48)	236 (9.29)	60 (2.36)	400 (15.75)	360 (793.51)	6.5 (14.33)
1150 (45.28)	2530 (99.61)	170 (6.69)	236 (9.29)	60 (2.36)	600 (23.62)	280 (617.18)	8.7 (19.18)

*SWL calculated for 500mm wheelbase

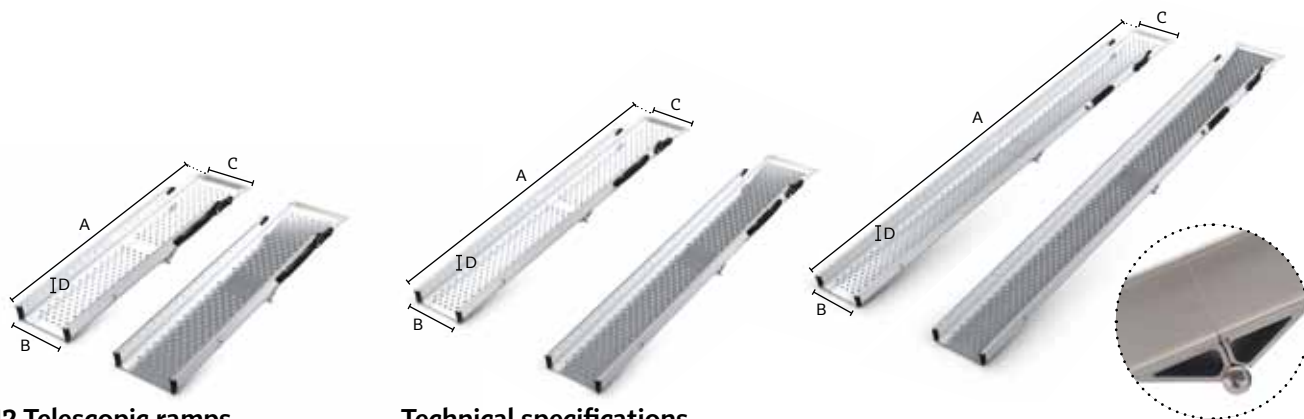

OV12 Telescopic ramps

Code	Description	Electric wheelchair use
OV12E-1100	Foldable - 2 pieces	YES
OV12E-1540	Foldable - 2 pieces	YES
OV12E-2300	Foldable - 2 pieces	YES

mm in

Technical specifications

Minimum length	Maximum length A	Internal width B	External width C	Side height D	Recommended height (13°)	Loading capacity (SWL*) pair	Weight per piece
						kg lbs	
550 (21.65)	1100 (43.31)	210 (8.27)	236 (9.29)	60 (2.36)	200 (7.87)	440 (969.85)	4.3 (9.48)
770 (30.31)	1540 (60.63)	210 (8.27)	236 (9.29)	60 (2.36)	300 (11.81)	400 (881.68)	5.3 (11.68)
1150 (45.28)	2300 (90.55)	210 (8.27)	236 (9.29)	60 (2.36)	500 (19.69)	300 (661.26)	7.8 (17.19)

*SWL calculated for 500mm wheelbase

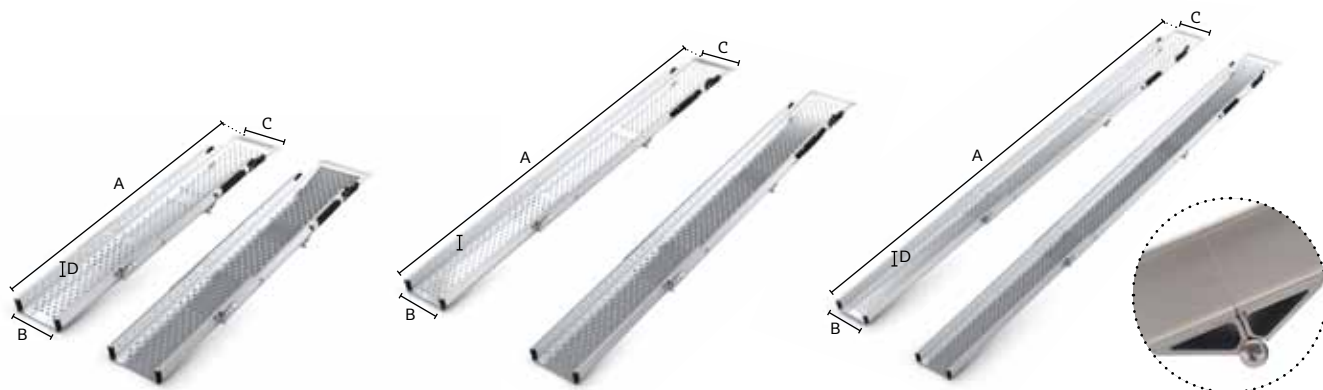

OV13 Telescopic ramps

Code	Description	Electric wheelchair use
OV13E-1440	Foldable and telescopic - 3 pieces	YES
OV13E-2100	Foldable and telescopic - 3 pieces	YES
OV13E-3240	Foldable and telescopic - 3 pieces	YES

mm in

Technical specifications

Minimum length	Maximum length A	Internal width B	External width C	Side height D	Recommended height (13°)	Loading capacity (SWL*) pair	Weight per piece
						kg lbs	
550 (21.65)	1440 (56.69)	190 (7.48)	236 (9.29)	60 (2.36)	300 (11.81)	400 (881.68)	5.6 (12.34)
770 (30.31)	2100 (82.68)	190 (7.48)	236 (9.29)	60 (2.36)	500 (19.69)	320 (705.34)	7.8 (17.19)
1150 (45.28)	3240 (127.56)	190 (7.48)	236 (9.29)	60 (2.36)	800 (31.50)	220 (484.92)	11.0 (24.25)

*SWL calculated for 500mm wheelbase

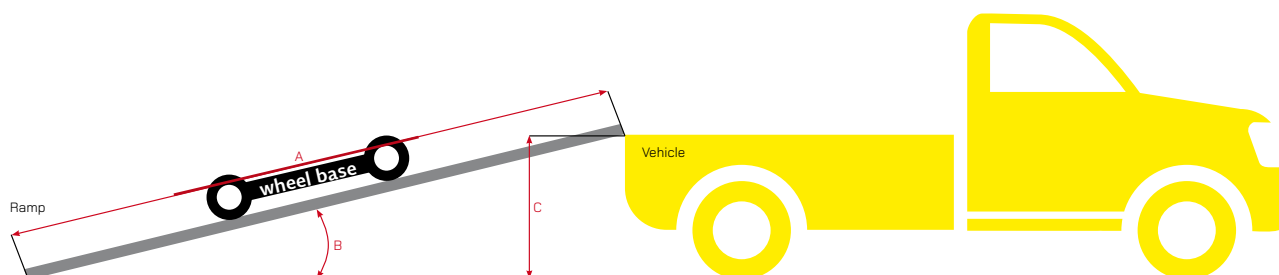



OV10,11,13

Smart locking system
Spring loaded pin with zinc-chrome plated hook to secure the telescopic ramp



OV10,11,12,13

Comfort handling bar
Ergonomic handling bar for easy manipulation



OV10,11,12,13

Regular or chamfered cuts
Regular cut design for manual wheelchair use.
chamfered cut design for electric (low profile)
wheelchair use



OV10,11,12,13

Friction and scratch protective rubber pad
Available for both regular and chamfered (low profile wheel) cut designs

